

# Project 01

## Visual Instructions

# PROJECT 01 | VISUAL INSTRUCTIONS CONTENTS

- ii Project 01 | Visual Instructions Contents
- iii Visual Instructions Mock-up/Photos
- iv Visual Instructions Final Art Wire-Frame
- v Visual Instructions full size screens
- vi Visual Instructions full size Screens
- vii Visual Instructions full size Screens
- viii Ponder | Project 01

## MODULE 01

- 2 Step 01 | Select a Task
- 3 Step 02 | Research: Visual Instructions Style
- 4 Step 03 | Research: Symbols, Icons, and Graphic Aids
- 5 Step 04 | Research: Visual Instructions Techniques/Strategies
- 6 Step 05 | Photographic Research: 1st Person view
- 7 Step 06 | Photographic Research: 3rd Person view
- 8 Step 07 | Visual Style concept sketches
- 9 Step 08 | Visual Style on a Mobile Phone
- 10 Video Notes | "A Communications Primer," by Charles & Ray Eames
- 11 Ponder | Module 01

## MODULE 02

- 13 Step 09 | Visual Style prototype
- 14 Step 10 | Refinements based on User Feedback
- 15 Ponder | Module 02

## MODULE 03

- 17 Step 11 | Visual Style Refinements & Final User Testing

## VISUAL INSTRUCTIONS MOCK-UP/PHOTOS



This mock-up is 1 step out of 6 to help special needs children through the process of completing a physical task. The task I chose was to set the table.

# VISUAL INSTRUCTIONS FINAL ART WIRE-FRAME

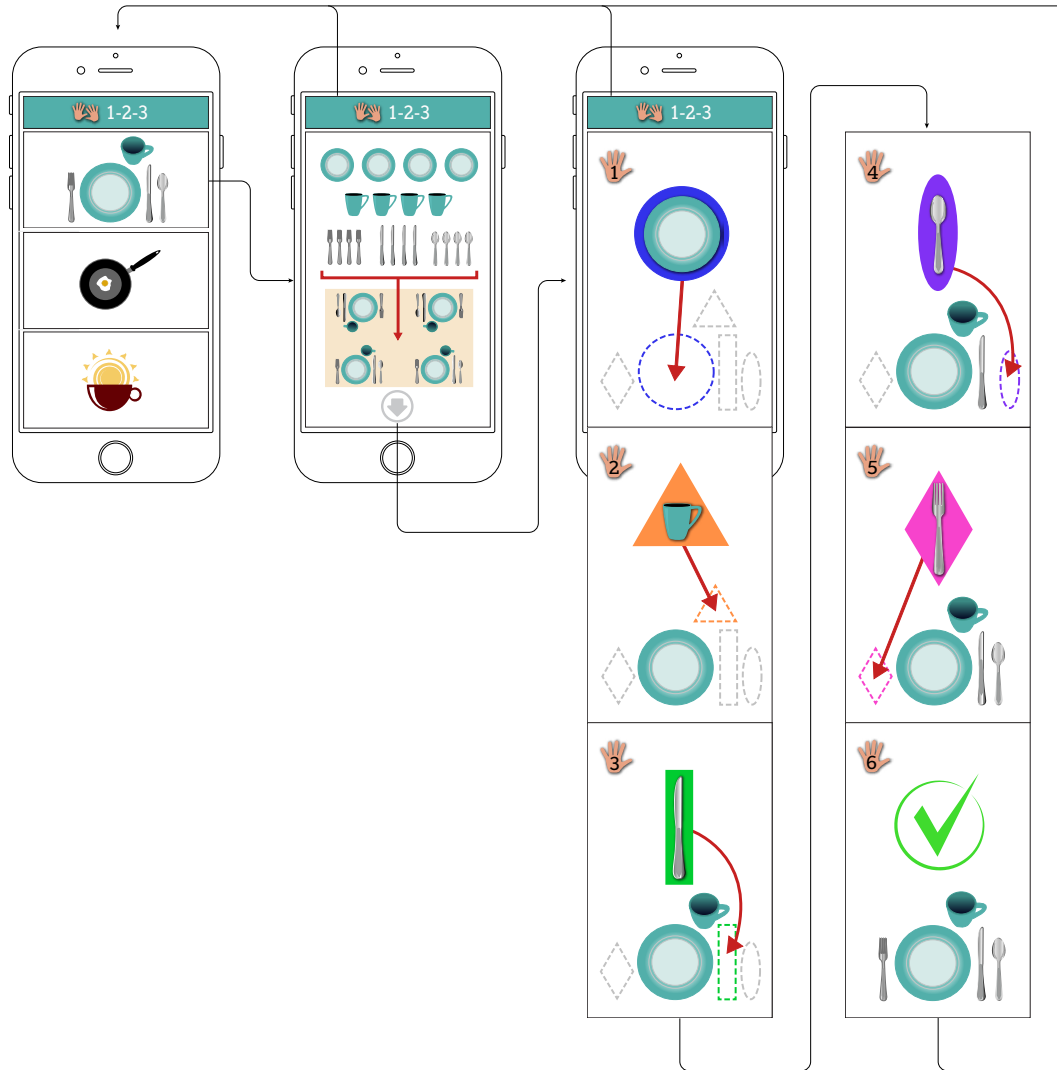

## Notes

Wireframe for 1-2-3 app for setting the table. Shows the interactive process of the app starting with the menu.

# VISUAL INSTRUCTIONS FULL SIZE SCREENS

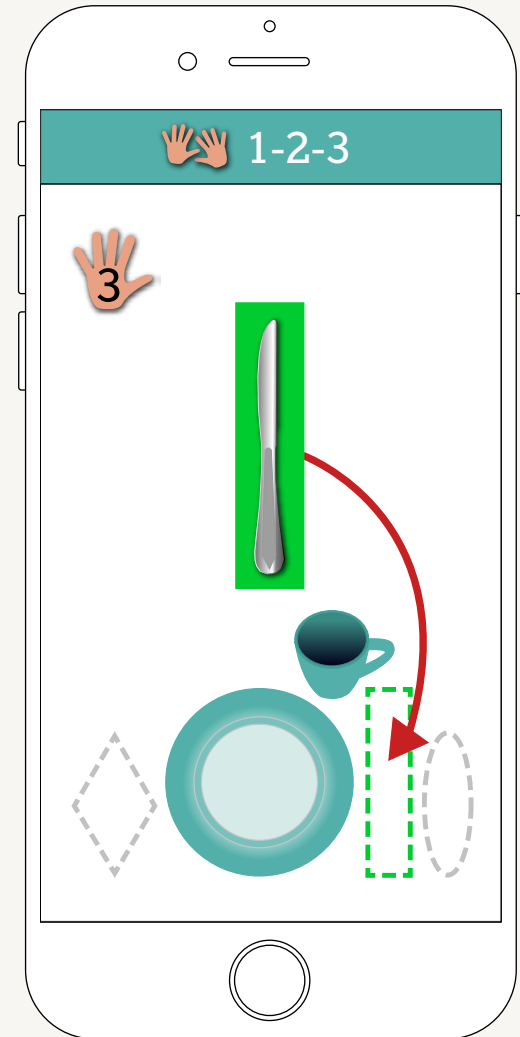
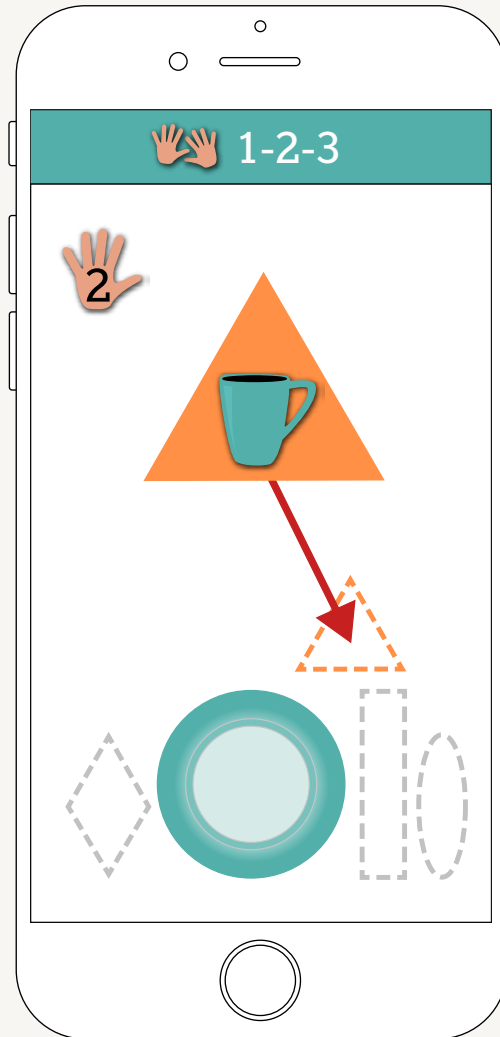
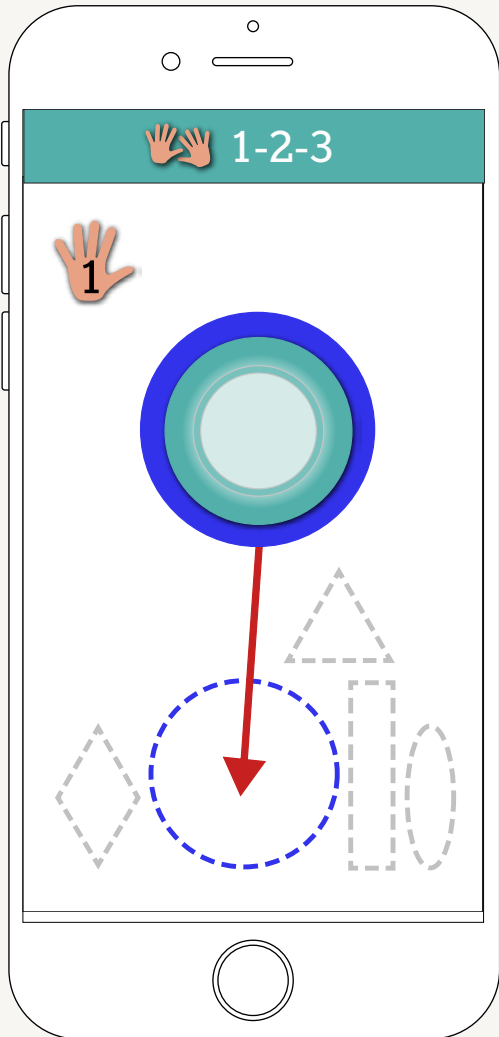

# VISUAL INSTRUCTIONS FULL SIZE SCREENS

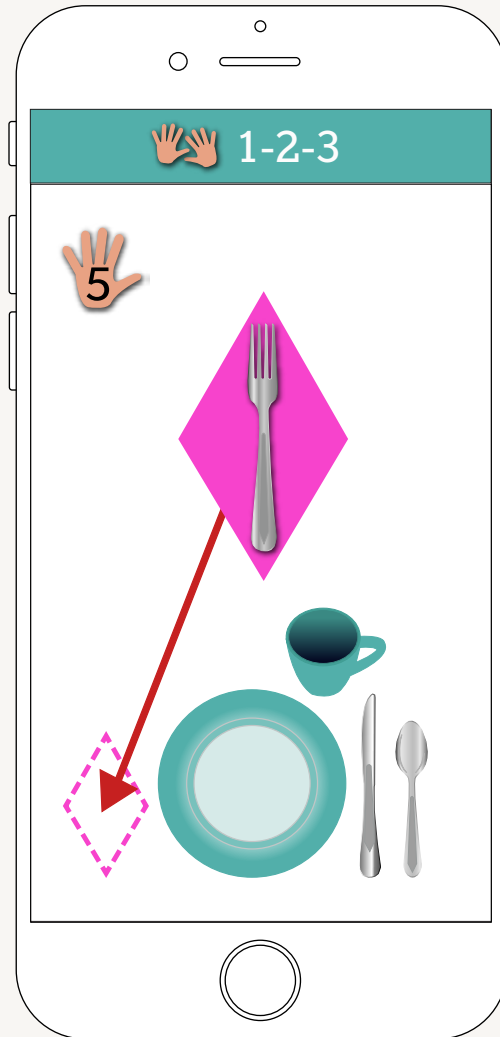
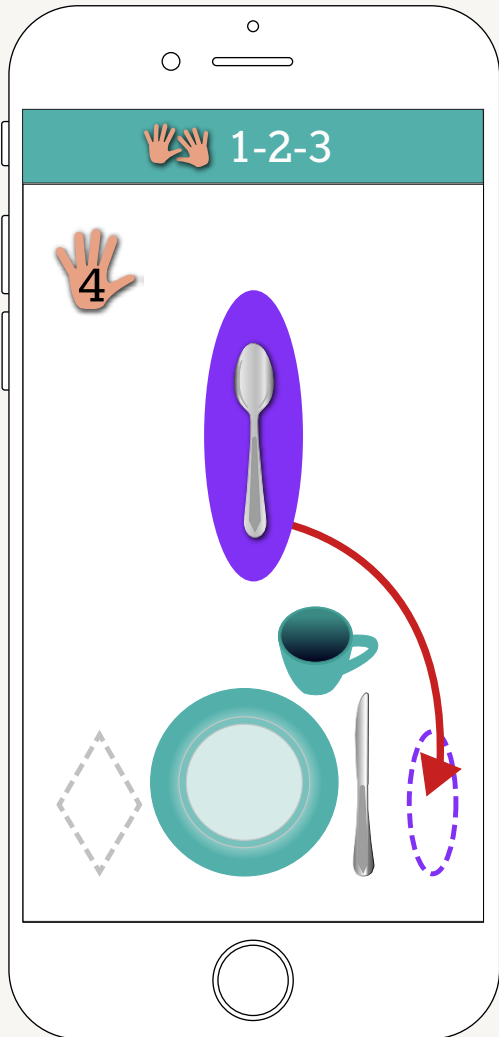

# VISUAL INSTRUCTIONS FULL SIZE SCREENS

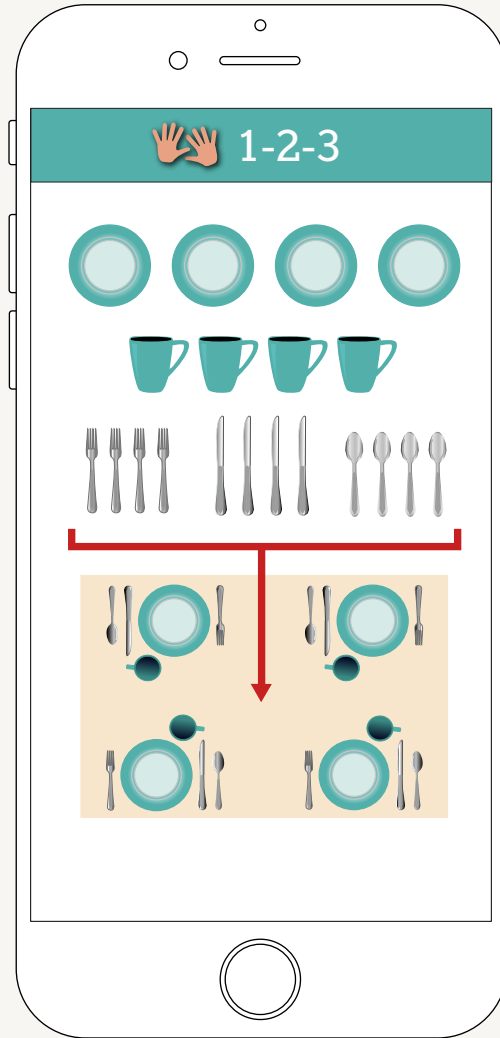
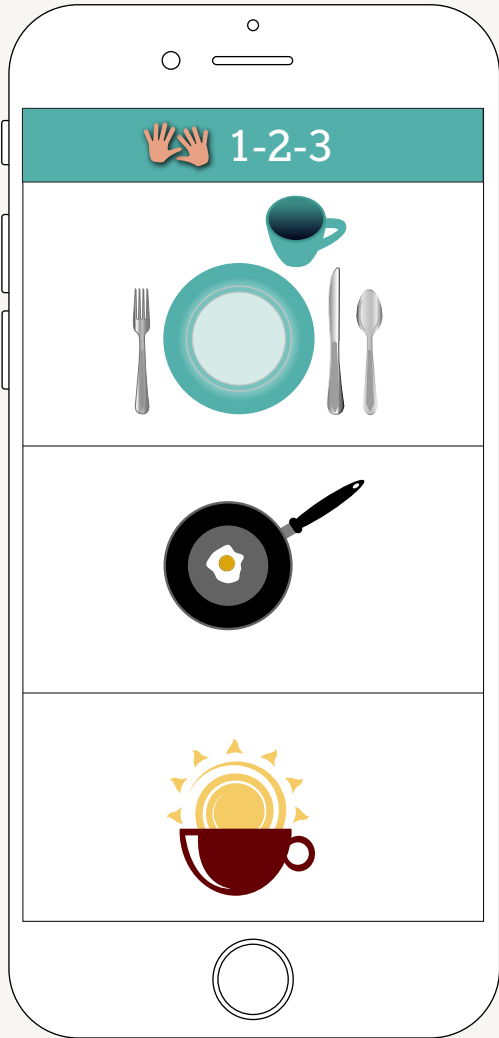

## PONDER | PROJECT 01

### What did you learn from the process of completing Project 01?

After the completion of project 1, looking back there was a lot I learned through out the process. This is the first time I've designed an app. I found the research portion the most essential to set the foundation for the project. I targeted someone that was familiar with the focus group of who would be using the app. I shared some of my ideas and she further expanded on them. She provided so much useful information in order to guide me in what direction I would decide to go in. I chose shapes and matching in order to help the kids visualize how the steps needed to be performed in order to set the table.

During the rough draft stages, I tried many different visual styles. I wasn't familiar with quite a few of the visual styles as far as isometric, mixed media, and exploded style. I original was going to use photographs in order to display the steps. I found out quickly that didn't come across very clean in design for this particular project. I proceeded to use my photos and convert them to Illustrator images. This was a good move and I think it helped present the material in a better way. I also originally had many different colors to represent the shapes. I found too much color sends confusing messages. I needed to simplify the design from there.

Simplify doesn't necessarily mean plain. In order to simplify I decided to gray out all the shapes so they were still present but have the focus on one shape out a time. This helped immensely to have the focal point on the specific step being displayed on screen.

The next process was testing the visuals with people. This proved to be very helpful. I learned that it's necessary to test your design before you go forward with the final adjustments. I tested 3 times and each time people would see things regarding the design to improve that I missed. On some of the feedback if it was just one individual making a comment about the design I would weigh it to see if it was necessary to make a change. However, if multiple people when testing had the same feedback I took that into consideration heavily to change. If multiple people were having the same problem with the steps a change had to be made.

Another aspect learned during this process was the importance of having up-to-date technology. In order for me to have access to the latest technology I am going to need to update my computer. There is lot of technology out there that is useful in making a digital prototype. I didn't even know that these processes existed but I can see the validity of it.

The feedback and critique discussion board I found very useful. I have learned over the course of these art classes to heavily rely on feedback. I've developed a pretty thick skin and know it's not an attack on me personally but to help the design to be as strong as possible.

### Sometimes you need to step away from your project to help let your mind think of what direction you want to go in.

One last thing I learned is sometimes you need to step away from your project to help let your mind think of what direction you want to go in. I became stuck and didn't know how I wanted to go about preceding. Usually, I push through until I can figure things out but I felt I needed to come back with a fresh pair of eyes. The inspiration finally came to me with using the shapes when I was showering. I asked my sister who is a para-educator if shapes would aid them to be successful in a task and she said yes. The more visually engaging and interactive the better for their minds.

# Module 01

“Something is happening. We are becoming a visually mediated society. For many, understanding of the world is being accomplished, not through words, but by reading images.”

—Paul Martin Lester

## STEP 01 | SELECT A TASK

### Task options (10 or more)

01. Folding a bath towel
02. Packing a lunch
03. Tying a shoe
04. Putting on the toilet paper roll
05. Brushing your teeth
06. Setting the table
07. Washing hair
08. Cook an egg
09. Make a fruit smoothie
10. Hand Washing

### Chosen task

I am going to be creating visual instructions on how to arrange an informal basic table setting for meals

### Needed materials

List needed materials (replace this content)

- plate, bowl
- fork, knife, spoon
- cup
- place mat
- napkin
- Table
- Table cloth

### Environmental considerations

My environment is going to be indoors in the dining room. I will need a table and a table cloth and a place mat to show an individual place setting.

### Units of measurement

No units of measurement will be necessary for my visual instructions.

### Chosen audience

My chosen audience will be youth 12-18.

They are at a point where they could start helping their parents but need a little direction through pictures in order to be successful.

My sister is a Paraeducator and said this is a great task to show in pictures. She said within this age group photographs work really well as well as illustrated pictures to show the placement of each piece of tableware. She mentioned many of her students are unable to talk so colorful pictures help them immensely to do tasks. They love to match shapes and colors together. Pictures in their simplistic form are the best for them to understand visual instructions.

## STEP 02 | RESEARCH: VISUAL INSTRUCTIONS STYLE

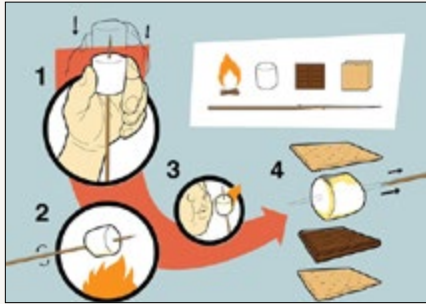

Flat Graphic Style



Photographic Style



Mixed Media Photographed Style

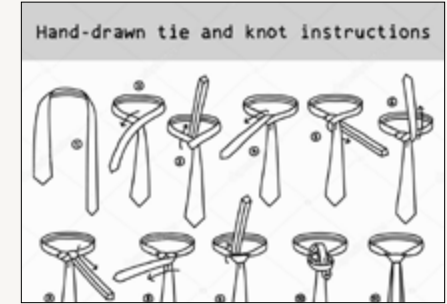

Hand Drawn Style

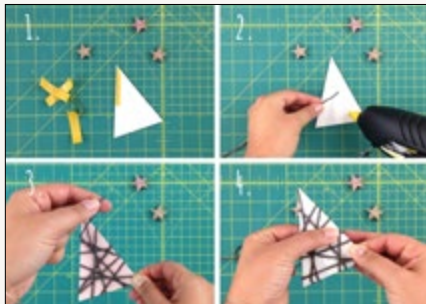

Top View Style

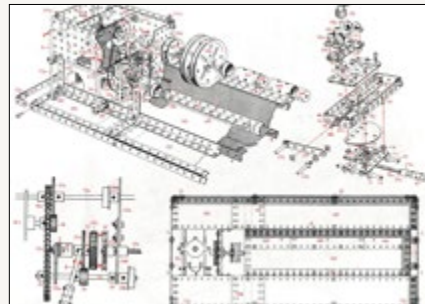

Exploded View Style

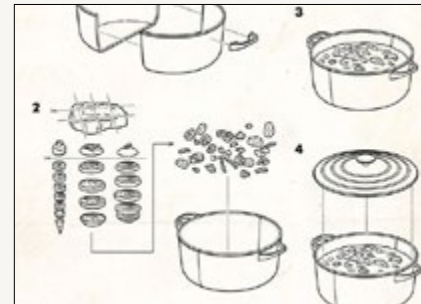

IKEA Style



Graphic Style

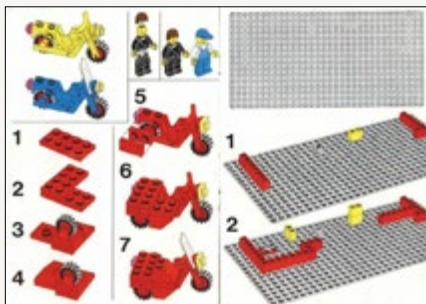

Illustrated Style



Line Drawing Style



Frame Style

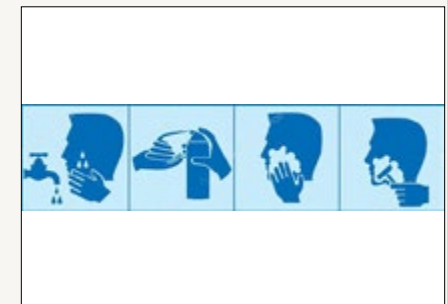

Icon Style

## STEP 03 | RESEARCH: SYMBOLS, ICONS, AND GRAPHIC AIDS



Pictogram indicating with arrows where to focus the camera.



Ideogram to indicate to read the instructions.



Indicate: The diagonal line indicates to protect from heat.

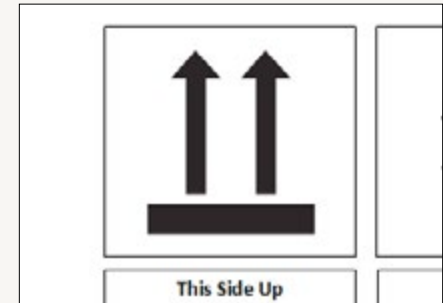

This symbol indicates by the arrows that this side needs to be up.



Icons that indicate the correct way and the wrong way.

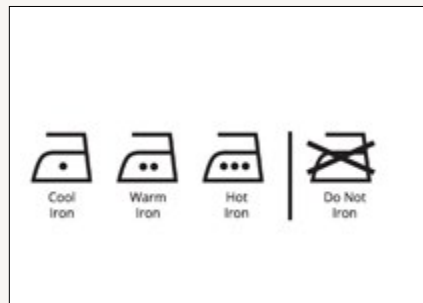

Symbols indicate what settings to iron a garment. The X indicates that the garment is not to be ironed.



This symbol indicates to push something.



The yellow symbol represents a warning or a caution. The color helps conveying the message of the symbol.



This pictogram indicates there is danger and to be careful when operating.



This is a symbol used to get your attention of things you should not do. A warning symbol!

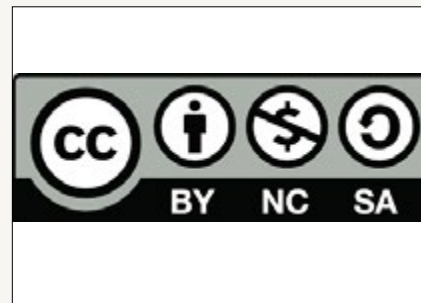

Various symbols to indicate gender, no money needed and can be reused.

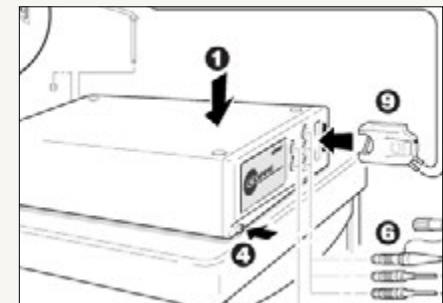

Arrow symbols are used to show exactly where to put components on a computer.

## STEP 04 | RESEARCH: VISUAL INSTRUCTIONS TECHNIQUES/STRATEGIES

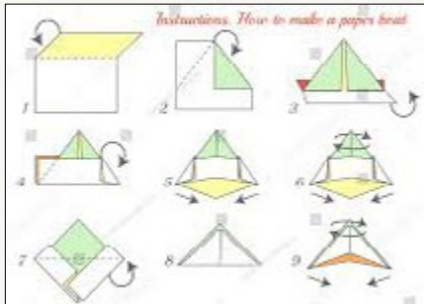

Color is used to help define the 3 dimensional nature of the folding.

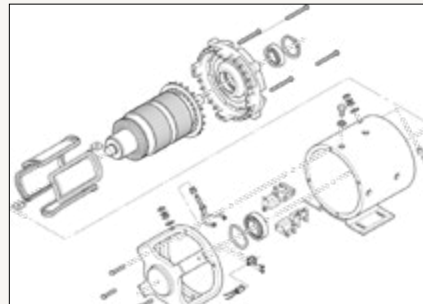

Exploded View is showing the pieces in close proximity to each other but pulled apart.

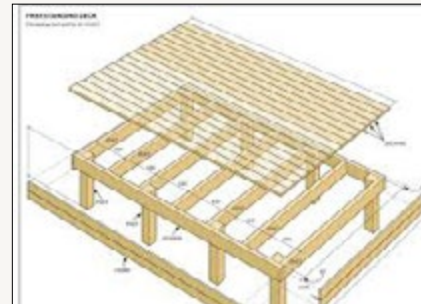

Wire frame Structure show was is underneath the top layer and how each of the beams fit together respectively.

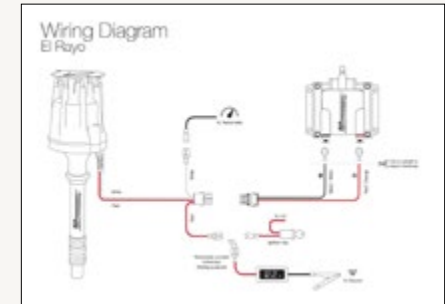

Exploded View shows the wires expanded and how they connect to each other.

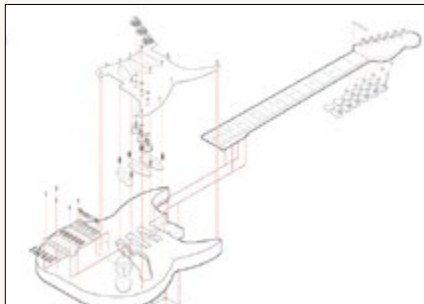

Isometric instructions shows the relationship to the pieces of the guitar.



Sub-steps are shown in beige to complete the small details of individual pieces.



This is an isometric instruction where all three dimensions are drawn.



Exploded View shows how they are in relationship to each other using arrows to direct the sequence.

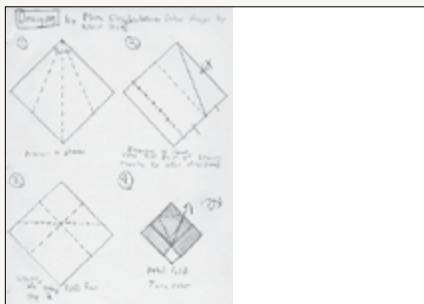

Using dotted lines to show where to fold and solid lines for already folded pieces.

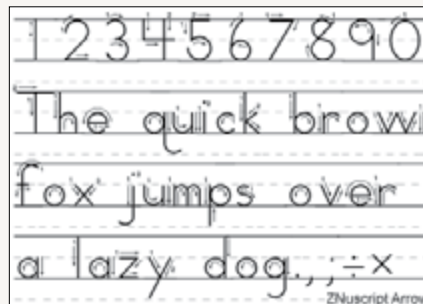

Using arrows to show the direction of where you need to go.

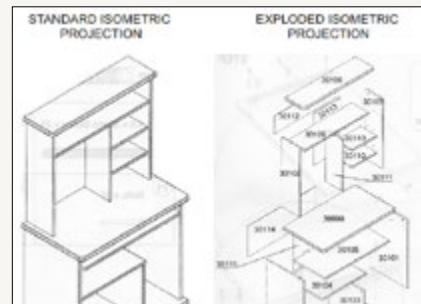

Shows an exploded isometric view of how each piece goes together along with the completed piece on the left.



Uses color in order to show where to apply the face mask.

## STEP 05 | PHOTOGRAPHIC RESEARCH: 1ST PERSON VIEW



Plate

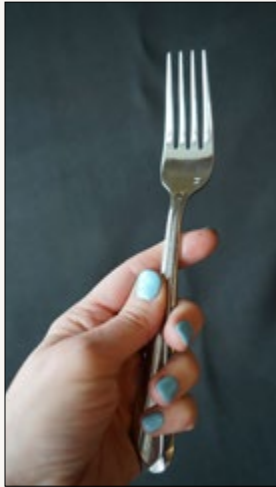

Fork



Spoon



Cup



Bowl

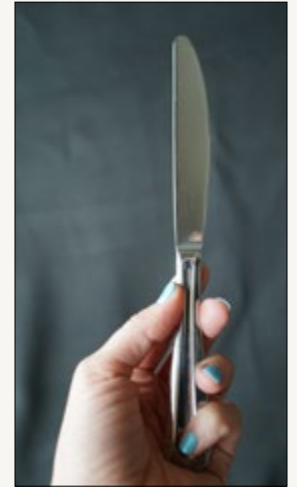

Knife



Step 01



Step 02



Step 03



Step 04



Step 05



Step 06

## STEP 06 | PHOTOGRAPHIC RESEARCH: 3RD PERSON VIEW



Plate



Cup



Bowl



Fork



Knife



Spoon

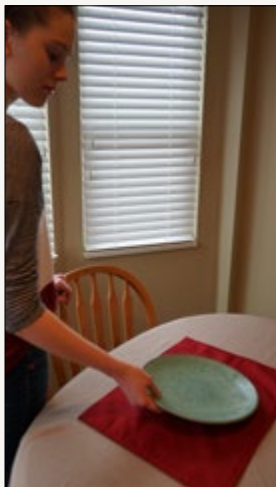

Step 01



Step 02



Step 03

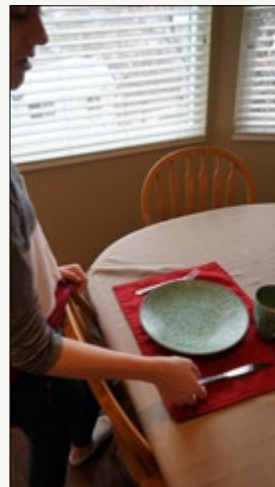

Step 04



Step 05

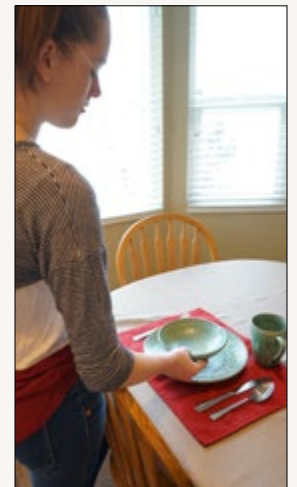

Step 06

## STEP 07 | VISUAL STYLE CONCEPT SKETCHES

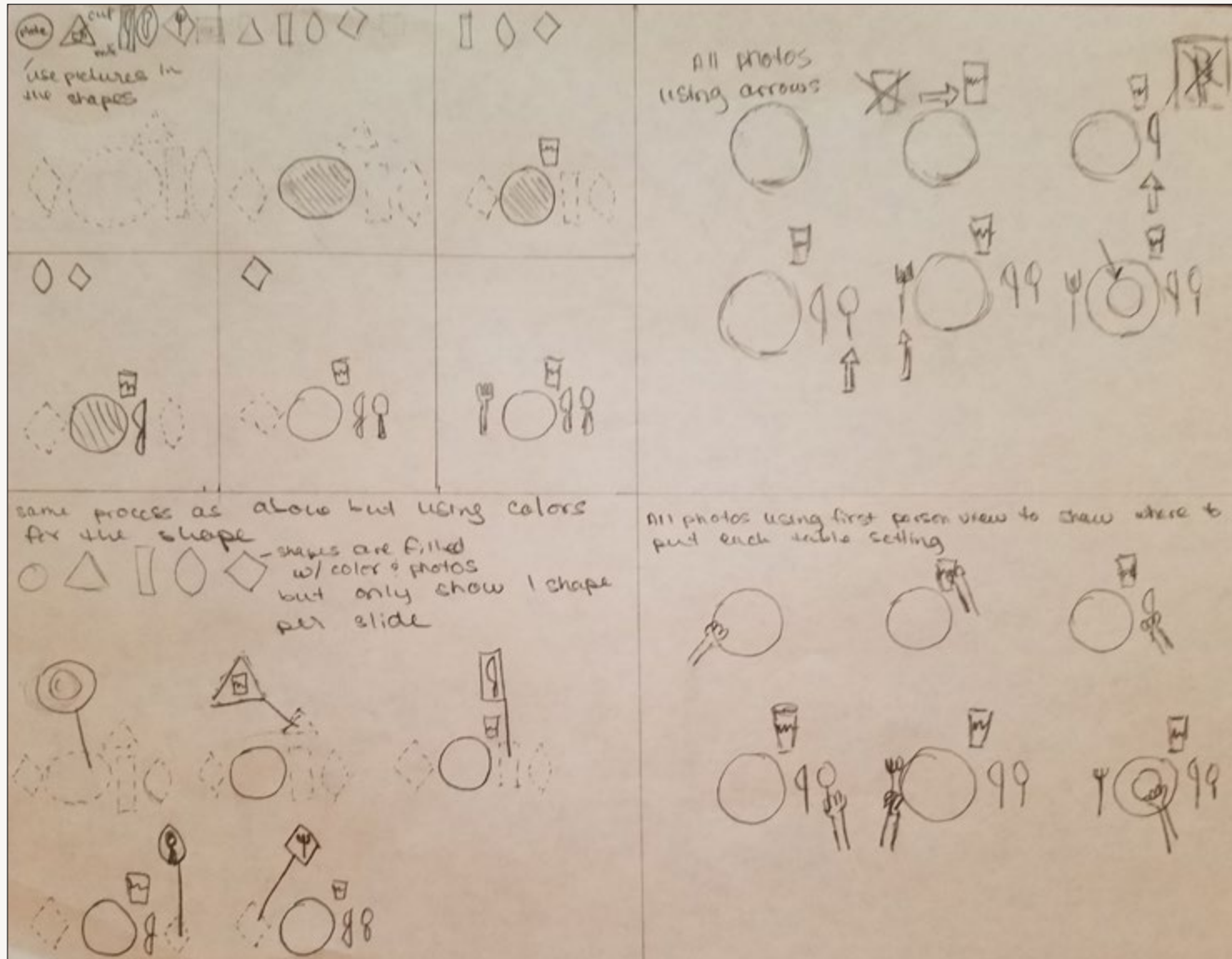

### Notes

A lot of the special need students are really good at matching shapes. I thought having the picture inside a shape or maybe the same color might help them match it. Maybe even make it an interactive app to help them think where the table settings might go.

## STEP 08 | VISUAL STYLE ON A MOBILE PHONE

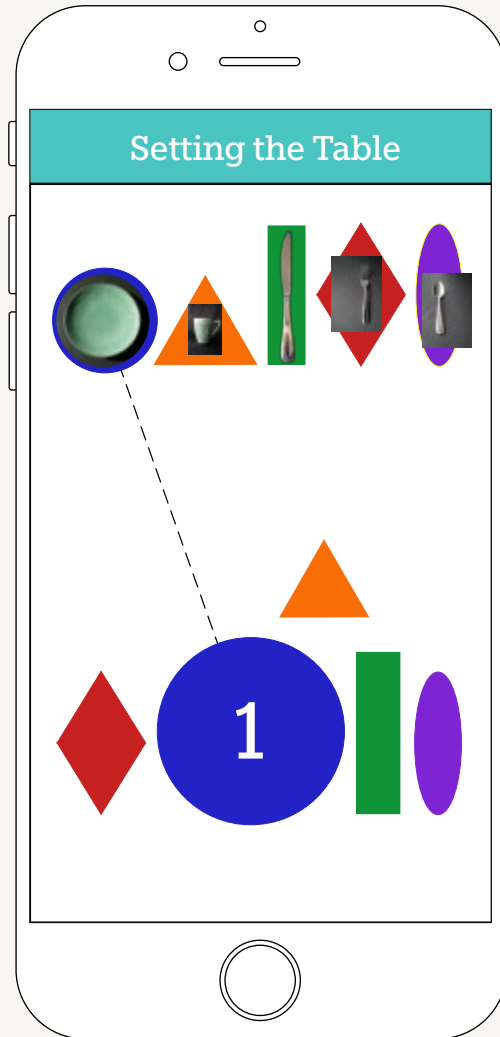
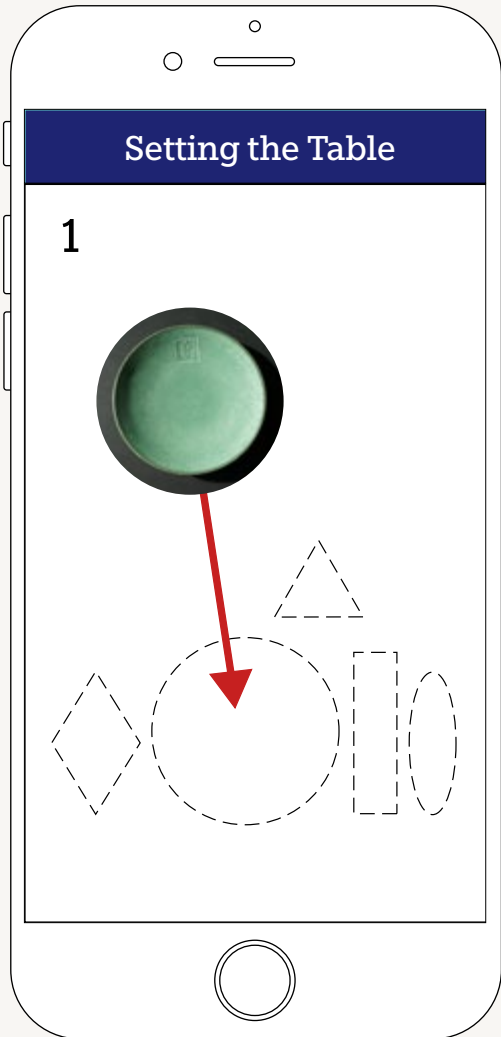

## VIDEO NOTES | “A COMMUNICATIONS PRIMER,” BY CHARLES & RAY EAMES

### **What are the important components of Claude Shannon’s Diagram on communication? (1:26)**

The Communication of Information Source, Signal, Transmitter, Communication channel to the Receiver, and Noise Source all contribute to the components of Claude Shannon’s Diagram.

### **Anything that interferes with or distorts the communication is called what? (1:26)**

Anything that interfere or distorts communication is referred to as noise. Noise is not necessarily sound it’s also different light sources, flashing lights, and movement.

### **How do you combat distortion of information when attempting to communicate clearly? (5:17)**

Redundancy in the message is used to clearly communicate and helps to eliminate distortion of the message. Increasing the power of the transmitter but duplicating other signals mean showing difference instances of the original signal.

### **Why would it be so important to understand your audience when attempting to communicate clearly to them?**

We all receive information in our own unique way when communicating. If I don’t understand who my audience is there is more room for error when

trying to convey a message when relying on just my own understanding.

### **How are the concepts in this video relevant to your chosen discipline or profession?**

If and when I take on clients to design digital artwork or infographics, I will have to have a clear idea what their company stands for and understand their business dealings in order to effectively create material that will communicate the purpose.

### **Please indicate any other concepts within this video that are relevant or important to this project or your career.**

In the video they briefly mentioned how color and spacing can change how things can be communicated depending on the placement.

Signals need to be universal. It’s hard to communicate information if the receiver does not understand the same information that the transmitter is giving. They gave the example you would not speak Chinese to someone who did not understand the language.

Communication links people together. It holds people together and keeps them apart simultaneously.

Color and form contribute to how objects and symbols communicate.

Many different parts make a whole in order to communicate. They work in conjunction with each other to get the message to the receiver.

It’s important to have a clear view of who your audience is in order to know which visual communication is going to be the most effective. We could design something that looks aesthetically appealing but unless it has meaning to the receiver the message could get lost. Not everyone has the same knowledge and learning as each other. Communication visually needs to be in a way that is universally understood.

Some of the responsibilities I have as a designer is to know in depth the needs of the company or the person I’m designing for. It’s important to research what they stand for and who their audience is. Different signals can be more effective depending on who is receiving the information.

## PONDER | MODULE 01

### **What do you hope to gain from this course?**

This is my fourth art course in graphic design and I'm hoping to gain more confidence in my design skills and push beyond the limitations I have mentally put on myself. I like to receive beneficial feedback on my work so I can know how to improve the designs I'm working on. I understand the importance of feedback and critique and look forward to that aspect of the class.

There is so much to learn from the Adobe programs and hopefully during this class I can add to what I already know about the programs and find new ways to use the software to effectively design.

I also would like to get a firm grasp of how to present technical information in a digital format. I love to organize information and I'm hoping to learn ways to be able to present that information visually in an effective way.

### **What did you learn this week that you didn't know before?**

This week when we were researching different visual instructions, I didn't have a clear grasp of what 3rd person view was in regards to photography. I researched on the internet different examples. The instructor also explained 1st person view was from the individuals vantage point and

3rd person view was as if you were watching someone complete the task. I also learned what exploded and isometric view was.

### **Which design principles are you thinking about when you design?**

Some of the design principles I was thinking about while structuring one of the steps of the app were hierarchy, alignment, and white space. I tried to think of how to position the elements on the page that your eyes could move around the step but have it display in an order that was understandable. It may help the hierarchy in the design to increase the size of the top shape with making it bigger than the shapes below to show dominance.

I'm always checking to see if the elements have a strong connection with each other through alignment. As I make adjustments to the photos and design elements on the page, I'll need to be adjusting the alignment of the elements.

White space is going to be important in this app to help the eyes focus on the task at hand. A lot of space around the elements will highlight the specific steps.

### **Did you learn something new or are there challenges you are facing with the software?**

I'm not facing any challenges yet with the software. However, I'm worried about combining my modules in the book towards the end of the project. In each of my previous classes when I do this something happens within InDesign where it loses the formatting of all my columns and creates over set text. I have yet to resolve this problem and it's very frustrating. In the past I have just used Adobe Acrobat to combine the pdf's as a whole. I've learned my lesson in keeping a backup of each of my modules in case this happens again. None of my instructors have been able to help with why this would be happening. I would love feedback if there are any instances where this has happened to others when trying to combine their modules in a process book. As far as I can tell from the forums online there may be a bug in the software when combining the files in a book that disrupts the columns of the formatted pages.

I have tried locking the columns and text to prevent this from happening and there was no change in the outcome.

# Module 02

“Design is an expression of the purpose, and it may (if it is good enough) later be judged as art; design depends largely on constraints and it is a method of action (there are always constraints and these usually include ethic).”

—Charles Eames

## STEP 09 | VISUAL STYLE PROTOTYPE

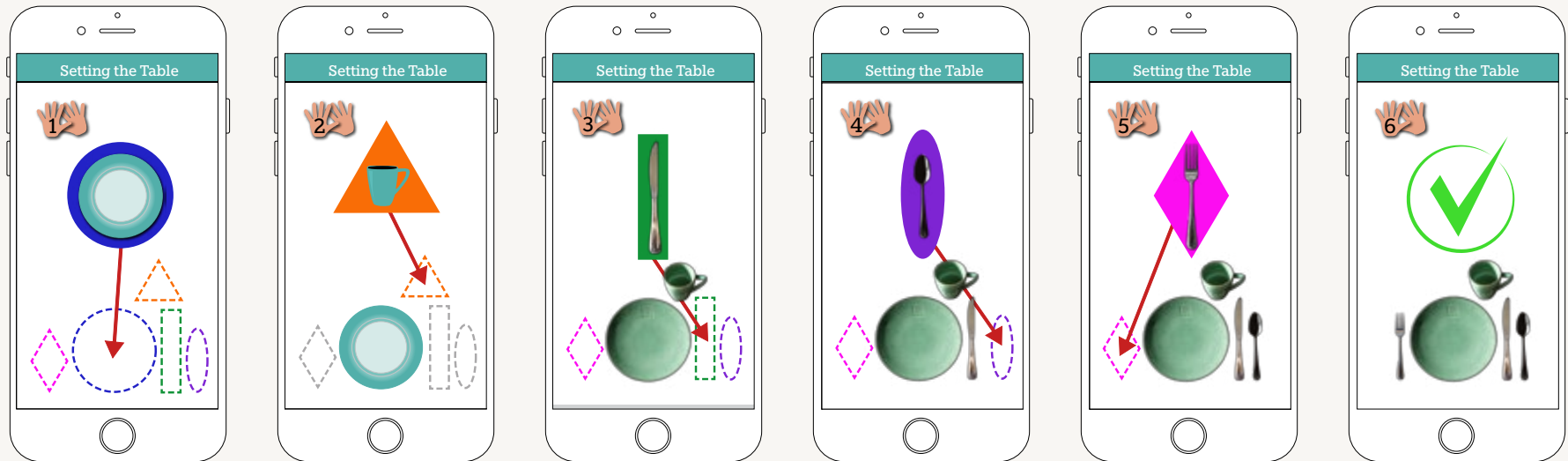

Record User 1 Reactions

Oh it's a dinner plate  
It's a hands on project  
What am I supposed to do?

Record User 2 Reactions

The hands tell me I need to  
use my hands for this. I'm  
confused what to do with the  
other shapes

Record User 3 Reactions

Put the round thing where  
the round thing goes

Record User 1 Reactions

Second made more sense  
Looks easy and it would help  
to show my kids to set a table

Record User 2 Reactions

Oh, the shapes are  
placeholders where to put the  
silverware

Record User 3 Reactions

The colors and the shape are  
both telling me where to put  
the cup

Record User 1 Reactions

Color is competing with the  
plate color

Record User 2 Reactions

Need more details

Record User 3 Reactions

I want to move the shape to  
other shape but it's not as  
easy to tell it's a knife because  
of the shape. Shading is not  
helping

Record User 1 Reactions

Looks like your supposed to  
slide the utensil under the cup

Record User 2 Reactions

Teaches where to put the  
spoon I guess

Record User 3 Reactions

Easy to see it's a spoon. The  
color and the shape and  
arrow help identify where to  
move it

Record User 1 Reactions

Love the purple easy to follow

Record User 2 Reactions

The table is complete I think

Record User 3 Reactions

Fork is easy to identify. Very  
clear what it is and where  
it goes.

Record User 1 Reactions

That makes me happy I'm  
done I did it.

Record User 2 Reactions

The table is officially  
complete...epic win

Record User 3 Reactions

Green check shows me that  
I've done something right and  
I'm done.

## STEP 10 | REFINEMENTS BASED ON USER FEEDBACK

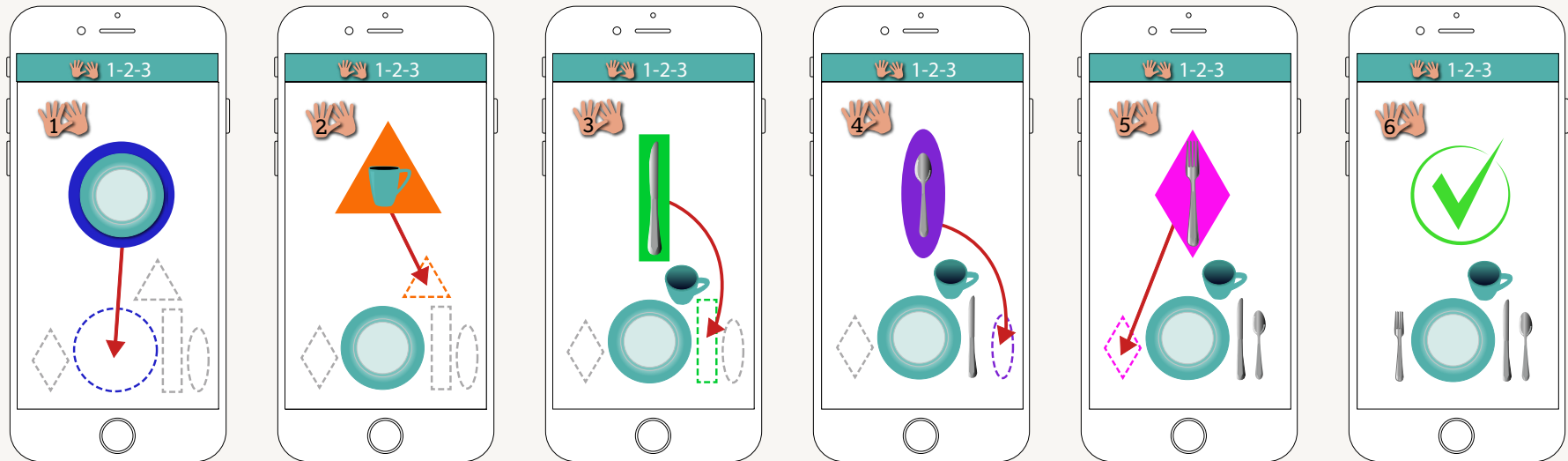

Record User 1 Reactions

Place setting might be better if it's on the top.

Record User 2 Reactions

Hands show it's first step  
The circle inside the circle confuses me.

Record User 3 Reactions

Hands show the first step then you drag the circle into the circle

Record User 1 Reactions

Looks good

Record User 2 Reactions

I need to match the shape

Record User 3 Reactions

Drag the triangle. Don't know why you're showing me the extra shapes right now.

Record User 1 Reactions

Makes sense where the knife goes

Record User 2 Reactions

Looks like it's almost done

Record User 3 Reactions

Show the shapes as you go one by one

Record User 1 Reactions

Don't like your spoon picture because it's black on the edge

Record User 2 Reactions

The spoon needs different shading

Record User 3 Reactions

Drag the oval to the dotted oval

Record User 1 Reactions

Looks good

Record User 2 Reactions

Shading is weird

Record User 3 Reactions

Do you really need the hands?

Record User 1 Reactions

I know I'm all done!

Record User 2 Reactions

Yay, I've accomplished setting the table.

Record User 3 Reactions

You have a complete table

## PONDER | MODULE 02

### How did user testing help you?

User testing proved to be very helpful this week. During the paper feedback, I received very useful reactions. Some of the things that were pointed out was the directional areas didn't look very good going underneath the cup to put down the silverware. It looked like you had to slide the silverware under the cup. It was suggested to put a curved arrow going around. It was also pointed out that some of the colors clashed and needed to be changed. The green was not showing very well so I ended up lightening up the color. I tried a yellow color but you couldn't see it very well on the screen.

For the digital prototypes it was mentioned the circle was confusing to have the plate on top of it being the same shape. I'm going to look into perhaps changing the circle to a square shape. I want the shapes to slightly resemble the place setting so I'm not sure if I want to implement that change or not. It was also brought up that I needed to work on the coloring of the silverware as it appeared too dark.

### What did you learn this week that you didn't know before?

This week I learned that my computer system is not going to cut it in my profession. In order to run some of the Adobe programs like XD

and Lightroom I have to have a Windows 10 Operating System. I like to have things last but unfortunately in the technology world you get left behind if you're not constantly updating your technology. I've been trying to find a short term solution until I can upgrade to the right computer at the right price. It's an investment for me since I will need the capabilities of a good computer for my profession. In the meanwhile I turned to my kid's computer to see if the OS could handle the requirements of the Adobe XD program. I found out we were with in the time frame of Dell having the drivers to support Windows 10.

### Which design principles are you thinking about when you design?

This week I was thinking about the drawing perspective and how you view things. I had to make a top view of my table settings as well as one from an angle. I used the photographs that I had taken the week earlier and converted them into vector graphics using Illustrator. I also tried using the principle of white space to my advantage in order to direct the eyes where I wanted the viewer's eyes to go. I purposefully made the object bigger on top and the place settings below smaller to create hierarchy.

### Did you learn something new or are there challenges you are facing with the software?

I got the OS successfully installed, then came complications with trying to get Adobe XD to work. When I downloaded the program I would just get a blank screen. I found out through forums that this problem is common. They offered a number of suggestions as to how to go about correcting the problem. We tried to clicking on the command to allow the administrator to make changes to this program. We finally went and updated the OS further with specific drivers for the graphics. After a number of hours and wondering if this is even going to work I was able to get the program to work. My next challenge would be copying all my work to my NAS box so I could share information via wireless to my kid's computer.

I found out quickly copying to the NAS box wasn't going to work. The wireless connection kept timing out when I went to transfer my files. I resorted to getting a flash drive and copying my files to that device so I could easily work back and forth between the two computers.

# Module 03

“ A painting is never finished - it simply stops in interesting places.”

—Paul Gardner

## STEP 11 | VISUAL STYLE REFINEMENTS & FINAL USER TESTING

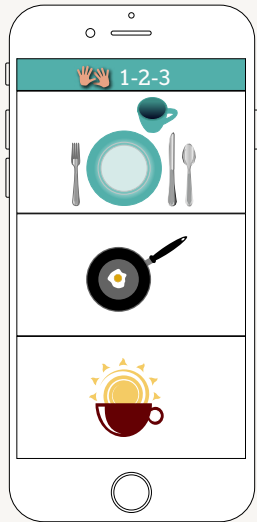

Record User 1 Reactions

Takes me to a page has an overall diagram, place set for four settings.

Record User 2 Reactions

Gather 4 place settings on the direction page

Record User 3 Reactions

I know to pick the menu item to initiate it

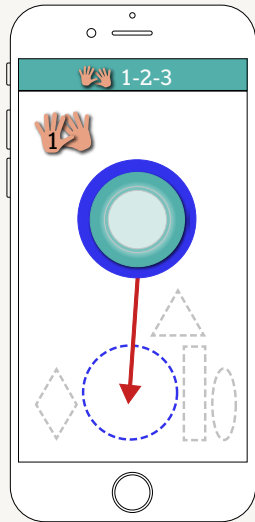

Record User 1 Reactions

I don't see the connection with the place setting until I get the second Semi-transparent image.

Record User 2 Reactions

Took me a moment to figure out the concept of the shapes. Put the plate in the circle

Record User 3 Reactions

Slide the plate to the circle

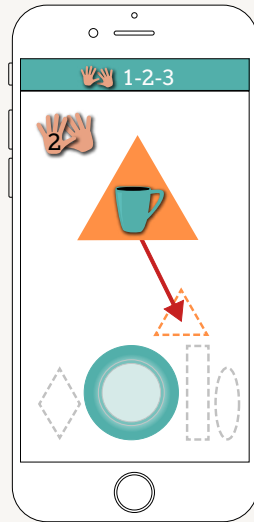

Record User 1 Reactions

Understand

Record User 2 Reactions

Put the cup in the triangle position

Record User 3 Reactions

Same thing drag the triangle to the dotted triangle

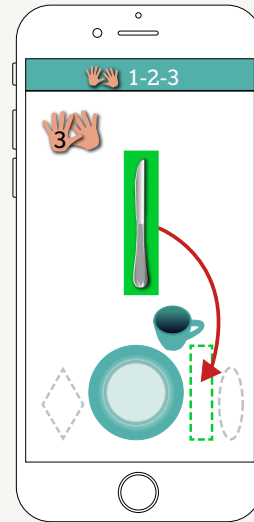

Record User 1 Reactions

Straight forward after that.

Record User 2 Reactions

Knife goes into rectangle. I like how you have shapes that makes it easy to understand.

Record User 3 Reactions

Drag the shape around the cup which is cool

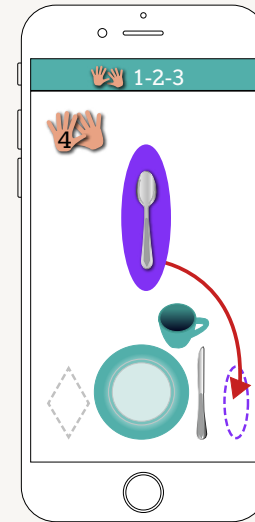

Record User 1 Reactions

Straightforward

Record User 2 Reactions

Spoon goes into shape

Record User 3 Reactions

Pretty obvious to put the spoon next to it.

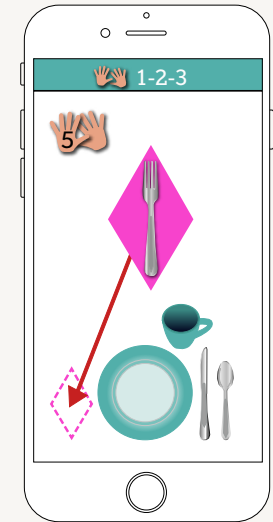

Record User 1 Reactions

Shape disappears as you progress.

Record User 2 Reactions

I like how the shapes are being replaced

Record User 3 Reactions

Drag the diamond down to the left and I know that I'm done in the last slide because it gave me a check mark